

APPROVAL SHEET

MULTI LAYER CERAMIC INDUCTOR

High Frequency Application Purpose

Size 0603 (1608)

WL1608 Pb-Free Series

*Contents in this sheet are subject to change without prior notice.

REVISION HISTORY

Rev	P/N	Description	Date
V01	WL1608 Green Material series	First Version	2004-10-07

FEATURES

1. Ceramic structure provides high reliability · high productivity
2. Product Design via 3D EM Simulation Skill makes excellent Q and SRF characteristics
3. Miniaturized size 1.6 x 0.8 x0.8 mm³
4. Pb Free products

APPLICATIONS

Portable electronics and wireless segment include mobile phones, WLAN, HomeRF, Bluetooth application, telecommunication and EMI countermeasure in high frequency circuits.

DESCRIPTION

Walsin Technology Corporation develops a tiny size of 1.6 x 0.8 x 0.8 mm³ Multi Layer Ceramic Inductor (MLCI) consists of a rectangular block of ceramic foils on which low resistive silver metal electrodes are contained and connected via through hole. The inner electrodes are then connected to the two terminations. Adopt 3D EM simulation skill for product design makes Walsin Technology Corporation MLCIs provide excellent Q_V Value and Self Resonant Frequency (SRF) characteristics to address application on high frequency band as well as on EMI suppression. The Walsin High frequency chip inductors are manufactured by Multilayer fabrication technology providing excellent electrical performance. The inductors are supplied in reel taping, making them suitable for automatic Pick & Place equipment. Cooperating with environmental protection, We provided Pb-Free products for customer request.

SHAPE AND DIMENSIONS

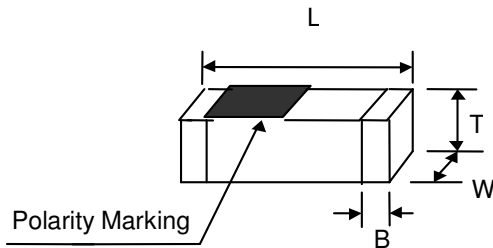

MARKING

Polarity mark



Unit: mm (inches)

	L	W	T	B
1608	1.6 [0.063] ±0.15 [0.005]	0.8 [0.031] ±0.15 [0.005]	0.8 [0.032] ±0.15 [0.005]	0.3 [0.012] ±0.20 [0.005]

Ordering Information

WL	16 08 08	G	4N7	S	G	T	03
Product Code	Dimension code	Material	Inductance	Tolerance	Specification	Packing Code	Rated Current
WL: Inductor	160808 = L: 1.6mm W: 0.8mm T: 0.8mm	A, B, C, D, E, F, G	For Ls < 10nH, N = Decimal Point e.g. 4N7 = 4.7nH	S: ± 0.3nH J: ± 5%	N= Normal A= ± 0.2nH G= Green	T= Reeled B = Bulk	03= 250mA or 300mA 02= 150mA or 200mA

ELECTRICAL SPECIFICATION – 0603 (1608) MLCI

Walsin Part Number	L(nH)	Tolerance	Q Min	Typical Q @ Frequency			SRF Typical (MHz)	RDC Maximum (Ω)	IDC (mA)
			(MHz)	100	100	800			
WL160808G1N0SGT03	1.0	$\pm 0.3nH$	8	13	44	60	8100	0.10	300
WL160808G1N2SGT03	1.2	$\pm 0.3nH$	8	13	44	60	8100	0.10	300
WL160808G1N5SGT03	1.5	$\pm 0.3nH$	8	14	37	56	8100	0.10	300
WL160808G1N8SGT03	1.8	$\pm 0.3nH$	8	12	37	55	8300	0.10	300
WL160808G2N2SGT03	2.2	$\pm 0.3nH$	8	12	38	54	8000	0.10	300
WL160808G2N7SGT03	2.7	$\pm 0.3nH$	8	13	38	53	7600	0.10	300
WL160808G3N3SGT03	3.3	$\pm 0.3nH$	8	12	37	49	5800	0.12	300
WL160808G3N9SGT03	3.9	$\pm 0.3nH$	8	14	44	62	5100	0.14	300
WL160808G4N7SGT03	4.7	$\pm 0.3nH$	8	15	43	63	4600	0.16	300
WL160808G5N6SGT03	5.6	$\pm 0.3nH$	8	15	45	59	4200	0.18	300
WL160808G6N8JGT03	6.8	$\pm 5\%$	8	15	43	58	3700	0.22	300
WL160808G8N2JGT03	8.2	$\pm 5\%$	8	15	44	52	3600	0.24	300
WL160808G10NJGT03	10	$\pm 5\%$	12	17	49	50	3500	0.26	300
WL160808G12NJGT03	12	$\pm 5\%$	12	15	41	37	2500	0.28	300
WL160808G15NJGT03	15	$\pm 5\%$	12	17	45	35	2600	0.32	300
WL160808G18NJGT03	18	$\pm 5\%$	12	16	45	39	2000	0.35	300
WL160808G22NJGT03	22	$\pm 5\%$	12	16	43	21	1800	0.40	300
WL160808G27NJGT03	27	$\pm 5\%$	12	16	41	11	1600	0.45	300
WL160808G33NJGT03	33	$\pm 5\%$	12	19	41	11	1500	0.55	300
WL160808G39NJGT03	39	$\pm 5\%$	12	19	42	17	1400	0.60	300
WL160808G47NJGT03	47	$\pm 5\%$	12	17	35	-	1300	0.70	300
WL160808G56NJGT03	56	$\pm 5\%$	12	19	31	-	1300	0.75	300
WL160808G68NJGT03	68	$\pm 5\%$	12	19	26	-	1150	0.85	300
WL160808G82NJGT03	82	$\pm 5\%$	12	19	21	-	1000	0.95	300
WL160808GR10JGT03	100	$\pm 5\%$	12	19	20	-	1000	1.00	300
WL160808GR12JGT03	120	$\pm 5\%$	12	19	16	-	950	1.20	300
WL160808GR15JGT03	150	$\pm 5\%$	12	19	-	-	800	1.50	300
WL160808GR18JGT03	180	$\pm 5\%$	12	19	-	-	750	1.90	300
WL160808GR22JGT03	220	$\pm 5\%$	12	18	-	-	680	2.20	300
WL160808GR27JGT03	270	$\pm 5\%$	12	20	-	-	600	2.50	300

【Test Instruments】

L.Q.: HP4291B (Text Fixture: HP16192A),
SRF: Anritsu 37247B,
RDC: HP4263B,
IDC: HP6612C

ELECTRICAL CHARACTERISTICS

Quality Factor vs. Frequency

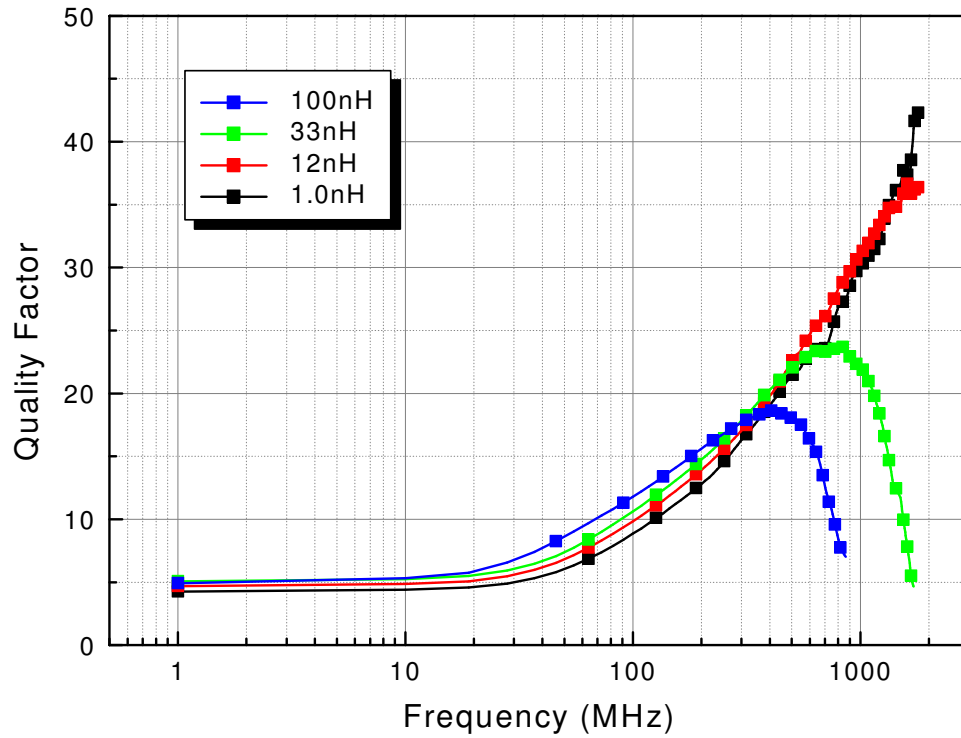

Inductance vs. Frequency

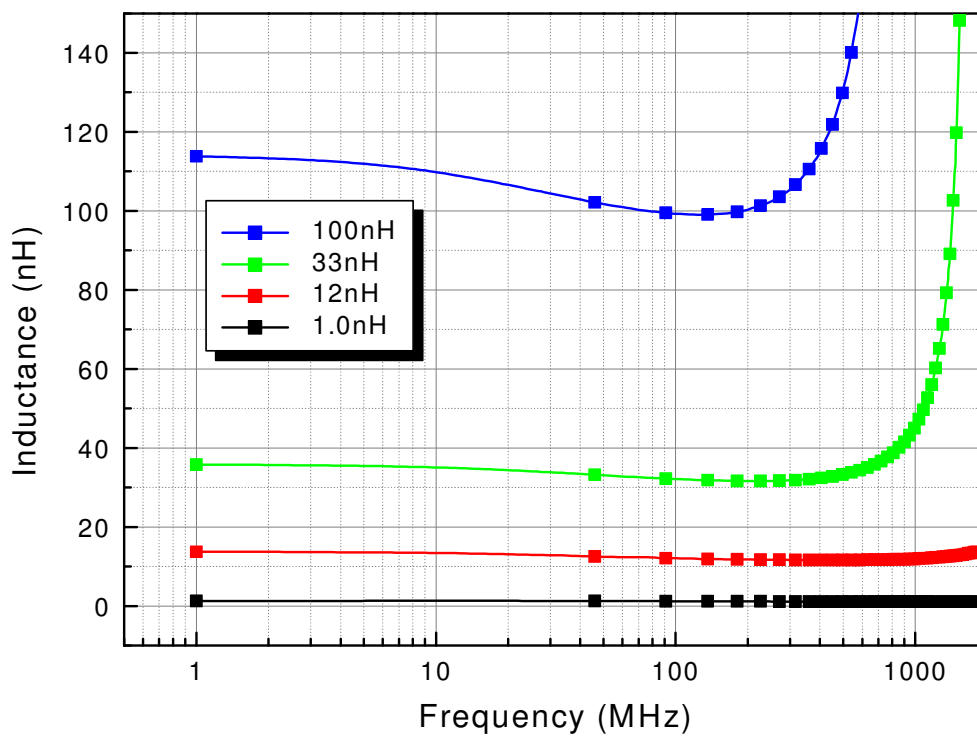

STANARD TEST and RELIABILITY TEST

- Temperature : 15~35°C
- Humidity : 25%RH~85%RH
- Atmospheric pressure : 96kPa ~ 106kPa

1. Electrical performance test

Item	Method & Criteria
Inductance/Q(Quality factor)	Unit : nH/Constant Test frequency : 100MHz Equipment : Impedance material analyzer
SRF(Self Resonant Frequency)	Unit : MHz Test frequency : Frequency sweep(40MHz~20GHz) Equipment : Network analyzer
DC(Direct Current)resistance	Unit : mΩ (ohm) Test frequency : LCR meter
Rated current	Unit : mA Test frequency : Current Sweep Equipment : Power supply (DC current source)

2. Reliability Test

TC	Unit : Temperature coefficient of L(PPM/°C) Test Temperature : -40°C~125°C(referring to L at 20°C) Equipment : TC Chamber(with Impedance analyzer, Ohmmeter, power supply PC, Printer) ◇ Basically, DC bias make no difference on L and Q, in glass ceramic inductors Requirements : L shall be within ±10% of the initial value.																				
Thermal Resistance (Temperature cycle)	Unit : Mechanical, Electrical Characteristics Test condition : <table border="1" style="margin-left: 40px;"> <thead> <tr> <th>Step</th> <th>1</th> <th>2</th> <th>3</th> <th>4</th> </tr> </thead> <tbody> <tr> <td>Temp.</td> <td>-40±2°C</td> <td>room temp.</td> <td>+125±2°C</td> <td>room temp.</td> </tr> <tr> <td>Time</td> <td>30min</td> <td>2-3min</td> <td>30min</td> <td>2-3min</td> </tr> <tr> <td>Cycle</td> <td colspan="4">100 cycles/test</td> </tr> </tbody> </table> Equipment : TC chamber or Temp. controlled chamber (programmable) Procedure : 1) Measure the initial values(L, Q, Rdc) 2) Carry out the test as described above 3) make measurements after ambient air exposure for 24±2 hours. Requirements : No apparent damage L shall be within ±10% of the initial value. Q shall be within ±20% of the initial value.	Step	1	2	3	4	Temp.	-40±2°C	room temp.	+125±2°C	room temp.	Time	30min	2-3min	30min	2-3min	Cycle	100 cycles/test			
Step	1	2	3	4																	
Temp.	-40±2°C	room temp.	+125±2°C	room temp.																	
Time	30min	2-3min	30min	2-3min																	
Cycle	100 cycles/test																				

<p>Humidity Resistance</p>	<p>Unit : Mechanical, Electrical Characteristics</p> <p>Test condition : Humidity ; 90-95%RH</p> <ul style="list-style-type: none"> • Temp :60°C • Time : 500±12 hours neglected. <p>Equipment : Constant temperature & humidity chamber</p> <p>Procedure : 1) Measure the initial values(L, Q, Rdc)</p> <p style="padding-left: 40px;">2) Carry out the test as described above</p> <p style="padding-left: 40px;">3) make measurements after ambient air exposure for 24±2 hours.</p> <p>Requirements : No apparent damage</p> <p style="padding-left: 40px;">L shall be within ±10% of the initial value.</p> <p style="padding-left: 40px;">Q shall be within ±20% of the initial value.</p>
<p>High Temperature Resistance</p>	<p>Unit : Mechanical, Electrical Characteristics</p> <p>Test condition : Temp.; 125±2°C</p> <p style="padding-left: 40px;">Time ;1000±12 hours under unloading.</p> <p>Equipment : Constant temperature & humidity chamber</p> <p>Procedure : 1) Measure the initial values(L, Q, Rdc)</p> <p style="padding-left: 40px;">2) Carry out the test as described above</p> <p style="padding-left: 40px;">3) make measurements after ambient air exposure for 24±2 hours.</p> <p>Requirements : No apparent damage</p> <p style="padding-left: 40px;">L shall be within ±10% of the initial value.</p> <p style="padding-left: 40px;">Q shall be within ±20% of the initial value.</p>
<p>Low Temperature Resistance</p>	<p>Unit : Mechanical, Electrical Characteristics</p> <p>Test condition : Temp.; -40 ±2°C</p> <p style="padding-left: 40px;">Time ;1000±12 hours under unloading.</p> <p>Equipment : Constant temperature & humidity chamber</p> <p>Procedure : 1) Measure the initial values(L, Q, Rdc)</p> <p style="padding-left: 40px;">2) Carry out the test as described above</p> <p style="padding-left: 40px;">3) Neglect sample in room temp. for 24 ±2 hours, then, make measurements.</p> <p>Requirements : No apparent damage</p> <p style="padding-left: 40px;">L shall be within ±10% of the initial value.</p> <p style="padding-left: 40px;">Q shall be within ±20% of the initial value.</p>

<p>8585 Test</p>	<p>Unit : Mechanical, Electrical Characteristics Test condition : Temp. ; 85±2°C . Humidity ; 85±5% .Time ; 100±12 hours Equipment : Constant temperature & humidity chamber Procedure :1) Measure the initial values(L, Q, Rdc) 2) Carry out the test as described above 3) Make measurements after the ambient air exposure for 24±2 hours Requirements : No mechanical damage L shall be within ±10% of the initial value. Q shall be within ±20% of the initial value.</p>
<p>Loading under Damp Heat</p>	<p>Unit : Mechanical, Electrical Characteristics Test condition : Temp :60±2°C . Humidity : 90~95%RH .:Time : 500±12 hours :Apply current: Rated current Equipment : Constant temperature & humidity chamber Procedure :1) Measure the initial values(L, Q, Rdc) 2) Carry out the test as described above 3) Make measurements after the ambient air exposure for 1 to 2 hours of recovery Requirements : No mechanical damage L shall be within ±10% of the initial value. Q shall be within ±20% of the initial value.</p>
<p>Loading at High Temperature</p>	<p>Unit : Mechanical, Electrical Characteristics Test condition : Temp :125±2°C :Time : 500±12 hours :Apply current: Rated current Equipment : Constant temperature & humidity chamber Procedure :1) Measure the initial values(L, Q, Rdc) 2) Carry out the test as described above 3) Make measurements after the ambient air exposure for 1 to 2 hours of recovery Requirements : No mechanical damage L shall be within ±10% of the initial value. Q shall be within ±20% of the initial value.</p>

PACKAGE SPECIFICATION

Carrier Tape Dimensions

- Carrier Tape material : Paper
- Dimension in millimeters

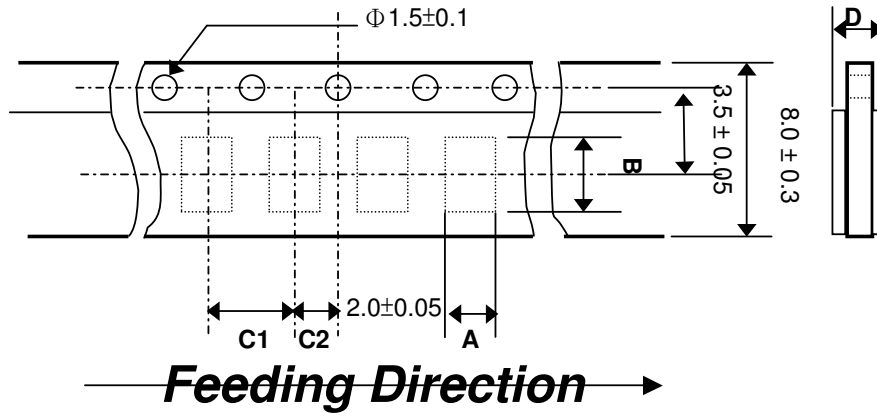

Series	Chip cavity	Chip cavity	Insertion pitch	Insertion pitch	Tape thickness
	A	B	C1	C2	D
1608	1.0 ± 0.1	1.8 ± 0.1	4.0 ± 0.1	2.0 ± 0.05	1.2max

Dimensions of Taping

-Leader and blank section

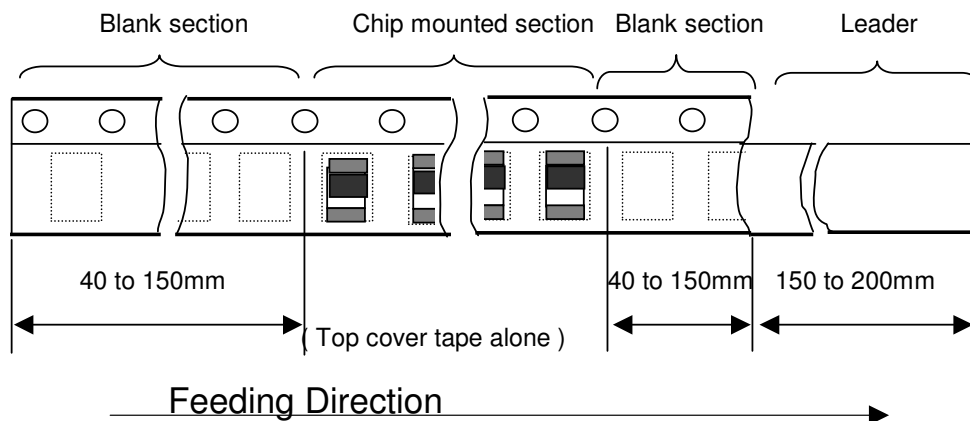

Appearance of taping

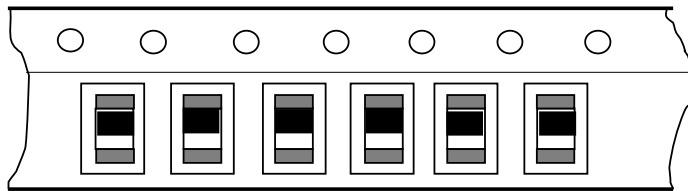
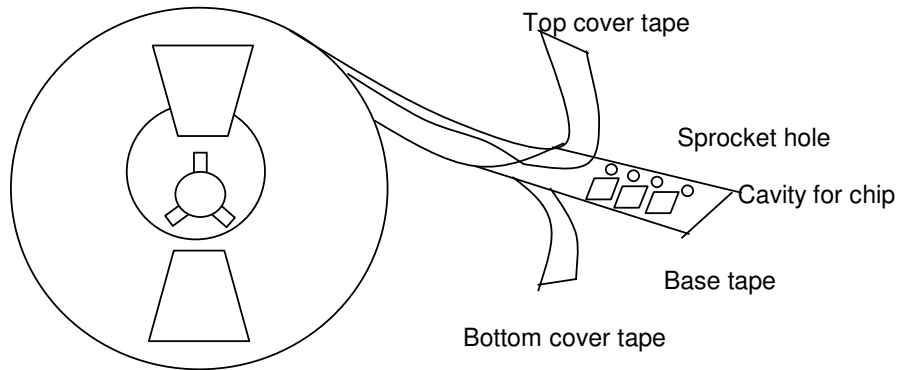

Packed chip

Reel Dimensions

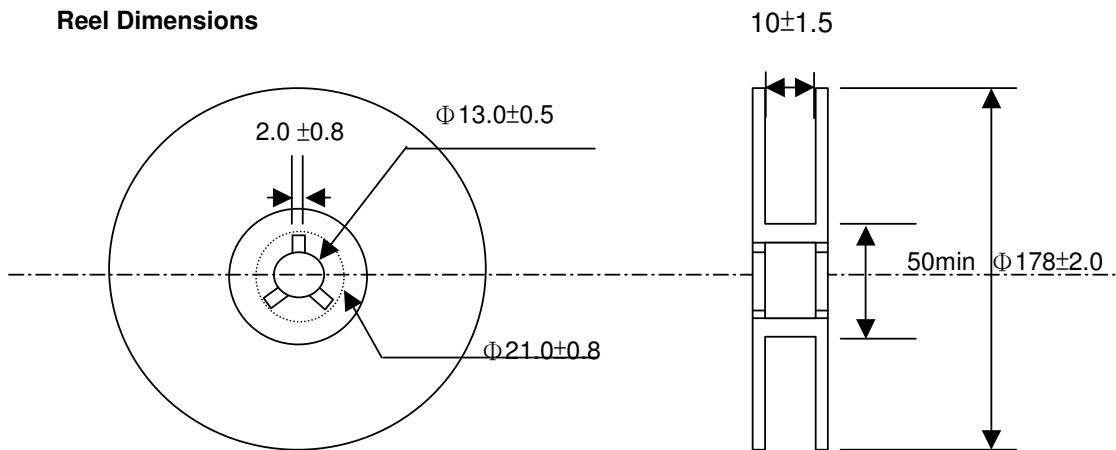

1. Reel material : Polystyrene
2. Ordering code No., Quantity, Batch No. and Walsin
3. Parts per reel : 4,000 pcs / reel

CAUTION OF HANDLING

Limitation of Applications

Please contact us before using our products for the applications listed below which require especially high reliability for the prevention of defects, which might directly cause damage to the third party's life, body or property.

- (1) Aircraft equipment
- (2) Aerospace equipment
- (3) Undersea equipment
- (4) Medical equipment
- (5) Disaster prevention / crime prevention equipment
- (6) Traffic signal equipment
- (7) Transportation equipment (vehicles, trains, ships, etc.)
- (8) Applications of similar complexity and /or reliability requirements to the applications listed in the above.

Storage condition

- (1) Products should be used in 6 months from the day of WALSIN outgoing inspection, which can be confirmed.
- (2) Storage environment condition.
 - Products should be storage in the warehouse on the following conditions.
 - Temperature : -10 to +40°C
 - Humidity : 30 to 70% relative humidity
 - Don't keep products in corrosive gases such as sulfur. Chlorine gas or acid or it may cause oxidization of electrode, resulting in poor solderability.
 - Products should be storage on the palette for the prevention of the influence from humidity, dust and son on.
 - Products should be storage in the warehouse without heat shock, vibration, direct sunlight and so on.
 - Products should be storage under the airtight packaged condition.