

APPROVAL SHEET

WR04X

±1%, ±5%

General purpose chip resistors

Size 0402

Customer : _____
Approval No : _____
Issue Date : _____

Customer Approval :



FEATURE

1. Small size and light weight
2. High reliability and stability
3. Reduced size of final equipment
4. Lower assembly costs
5. Higher component and equipment reliability
6. Lead free product is available

APPLICATION

- Mobile phone
- PDA
- Camcorders
- Pagers
- Palmtop computers

DESCRIPTION

The resistors are constructed in a high grade ceramic body (aluminum oxide). Internal metal electrodes are added at each end and connected by a resistive paste that is applied to the top surface of the substrate. The composition of the paste is adjusted to give the approximate resistance required and the value is trimmed to nominated value within tolerance which controlled by laser trimming of this resistive layer.

The resistive layer is covered with a protective coat. Finally, the two external end terminations are added. For ease of soldering the outer layer of these end terminations is a Lead-tin or Tin (Lead free) alloy.

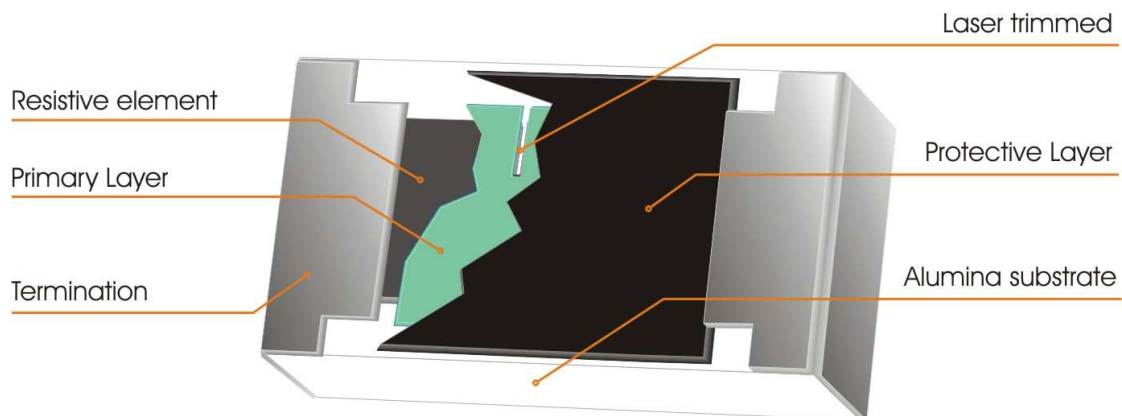

Fig 1. Construction of Chip-R WR04

QUICK REFERENCE DATA

Item	General Specification	
Series No.	WR04	
Size code	0402(1005)	
Resistance Range	1Ω~10MΩ(±5% tolerance), 10Ω~1MΩ(±1% tolerance), Jumper	
Resistance Tolerance	±1% E96/E24	±5% E24
TCR (ppm/°C)		
R≥1MΩ		-300~+500
1MΩ>R>10Ω	≤ ± 200	≤ ± 200
R≤10Ω	-300~+500	-300~+500
Max. dissipation @ T _{amb} =70°C	1/16 W	
Max. Operation Voltage (DC or RMS)	50V	
Max. Overload Voltage (DC or RMS)	100V	
Climatic category (IEC 60068)	55/155/56	

Note :

- This is the maximum voltage that may be continuously supplied to the resistor element, see "IEC publication 60115-8"
- Max. Operation Voltage : So called RCWV (Rated Continuous Working Voltage) is determined by

$$RCWV = \sqrt{\text{Rated Power} \times \text{Resistance Value}} \text{ or Max. RCWV listed above, whichever is lower.}$$
- For Resistance range 1Ω~10Ω and 1MΩ~10MΩ of tolerance ±1% series No. is WR04W, please refer to specification respectively.

Dimensions:

	WR04X
L	1.00 ± 0.05
W	0.50 ± 0.05
T	0.35 ± 0.05
Tb	0.25 ± 0.10
Tt	0.20 ± 0.10

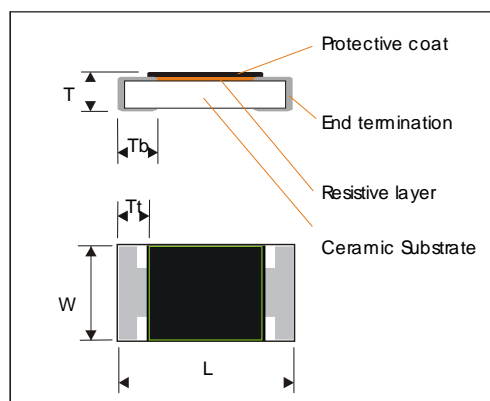

MARKING

WR04 has no marking on the product overcoat for both 5% & 1%.

FUNCTIONAL DESCRIPTION

Product characterization

Standard values of nominal resistance are taken from the E24 series for resistors with a tolerance of $\pm 5\%$, and E96 series for resistors with a tolerance of $\pm 1\%$. The values of the E24/E96 series are in accordance with "IEC publication 60063"

Derating

The power that the resistor can dissipate depends on the operating temperature; see Fig.2

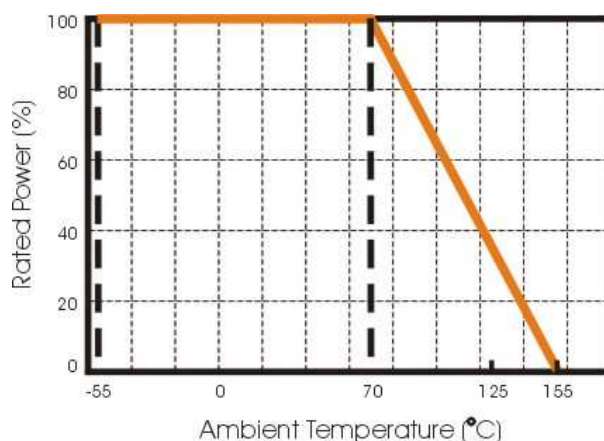

Figure 2. Maximum dissipation in percentage of rated power
As a function of the ambient temperature

CATALOGUE NUMBERS

The resistors have a catalogue number starting with :

WR04	X	3742	J	T	L
Size code WR04 : 0402	Type code X : Normal W : Out of resistance range (1% of 1Ω ~ 10Ω, 1MΩ~ 10MΩ)	Resistance code E24 : 2 significant digits followed by no. of zeros and a blank 4.7Ω =4R7_ 10Ω =100_ 220Ω =221_ Jumper =000_ ("_" means a blank) E96 : 3 significant digits followed by no. of zeros 102Ω =1020 37.4KΩ =3742	Tolerance F : $\pm 1\%$ J : $\pm 5\%$ P : Jumper	Packaging code T : 7" Reeled taping B : Bulk	Termination code L = Sn base (lead free)

1. Reeled tape packaging : 8mm width paper taping 10,000pcs per reel.
2. Bulk packaging : 10,000pcs per poly-bag



MOUNTING

Due to their rectangular shapes and small tolerances, Surface Mountable Resistors are suitable for handling by automatic placement systems.

Chip placement can be on ceramic substrates and printed-circuit boards (PCBs).

Electrical connection to the circuit is by individual soldering condition.

The end terminations guarantee a reliable contact.

SOLDERING CONDITION

The robust construction of chip resistors allows them to be completely immersed in a solder bath of 260°C for 10 seconds. Therefore, it is possible to mount Surface Mount Resistors on one side of a PCB and other discrete components on the reverse (mixed PCBs).

Surface Mount Resistors are tested for solderability at 245°C during 3 seconds. The test condition for no leaching is 260°C for 30 seconds. Typical examples of soldering processes that provide reliable joints without any damage are given in Fig 3.

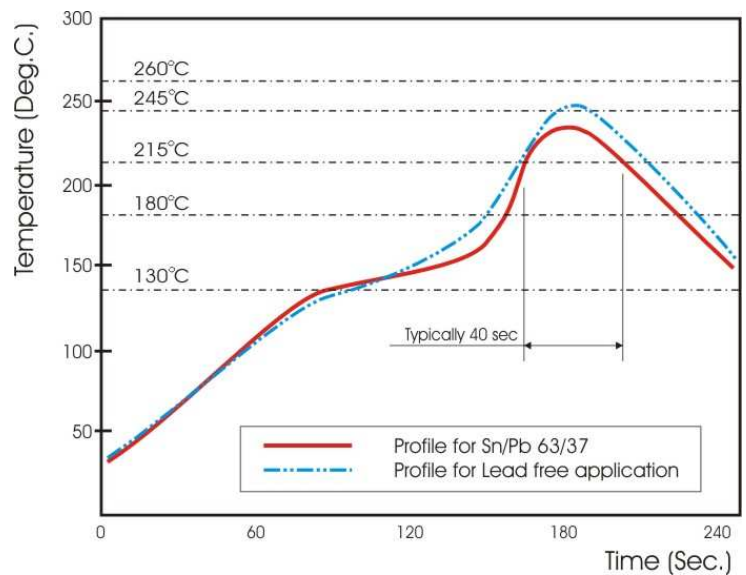

Fig 3. Infrared soldering profile for Chip Resistors WR04X

TEST CONDITION FOR JUMPER (0 Ω)

Item	WR04X
Power Rating At 70°C	1/16W
Resistance	MAX. 50mΩ
Rated Current	1A
Peak Current	1.5A
Operating Temperature	-55~155°C

TEST AND REQUIREMENTS(JIS C 5201-1 : 1998)

TEST	PROCEDURE / TEST METHOD	REQUIREMENT	
		Resistor	Ω
DC resistance Clause 4.5	DC resistance values measured at the test voltages specified below : <10Ω@0.1V, <100Ω@0.3V, <1KΩ@1.0V, <10KΩ@3V, <100KΩ@10V, <1MΩ@25V, <10MΩ@30V	Within the specified tolerance	<50mΩ
Temperature Coefficient of Resistance(T.C.R) Clause 4.8	Natural resistance change per change in degree centigrade. $\frac{R_2 - R_1}{R_1(t_2 - t_1)} \times 10^6 \text{ (ppm/}^\circ\text{C)}$ $t_1 : 20^\circ\text{C}+5^\circ\text{C}-1^\circ\text{C}$ R ₁ : Resistance at reference temperature R ₂ : Resistance at test temperature	Refer to "QUICK REFERENCE DATA"	N/a
Short time overload (S.T.O.L) Clause 4.13	Permanent resistance change after a 5second application of a voltage 2.5 times RCWV or the maximum overload voltage specified in the above list, whichever is less.	ΔR/R max. ±(2%+0.10Ω)	<50mΩ
Resistance to soldering heat(R.S.H) IEC 60068-2-58: 2004	Un-mounted chips completely immersed for 10±1second in a SAC solder bath at 255°C±5°C	Δ R/R max. ±(1%+0.05Ω) no visible damage	<50mΩ
Solderability IEC 60068-2-58: 2004	Un-mounted chips completely immersed for 3±0.3second in a SAC solder bath at 245°C±5°C	95% coverage min., good tinning and no visible damage	
Temperature cycling Clause 4.19	30 minutes at -55°C±3°C, 2~3 minutes at 20°C+5°C-1°C, 30 minutes at +155°C±3°C, 2~3 minutes at 20°C+5°C-1°C, total 5 continuous cycles	ΔR/R max. ±(1%+0.05Ω)	< 50mΩ
Damp Heat (Load life in humidity) Clause 4.24	1000 +48/-0 hours, loaded with RCWV or Vmax in humidity chamber controller at 40°C±2°C and 90~95% relative humidity , 1.5hours on and 0.5 hours off	10Ω≤R<1MΩ : ΔR/R max. ±(3%+0.10Ω) R<10Ω, R≥1MΩ : ΔR/R max. ±(5%+0.10Ω)	< 50mΩ
Load Life (Endurance) Clause 4.25	1000 +48/-0 hours, loaded with RCWV or Vmax in chamber controller 70±2°C, 1.5 hours on and 0.5 hours off	Ditto.	
Bending strength Clause 4.33	Resistors mounted on a 90mm glass epoxy resin PCB(FR4), bending once 5mm for 10sec.	No visual damaged, ΔR/R max. ±(1%+0.05Ω)	< 50mΩ
Adhesion Clause 4.32	Pressurizing force: 5N, Test time: 10±1sec.	No remarkable damage or removal of the terminations	
Insulation Resistance JISC5201-1:1998 Clause 4.6	Apply the maximum overload voltage (DC) for 1minutes	R ≥ 10GΩ	
Dielectric Withstand Voltage JISC5201-1:1998 Clause 4.7	Apply the maximum overload voltage (AC) for 1 minutes	No breakdown or flashover	

PACKAGING

Paper Tape specifications (unit :mm)

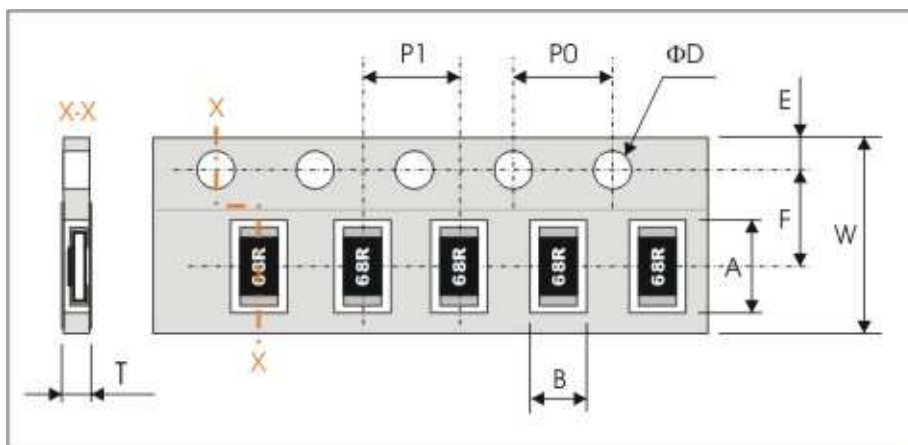

Series No.	A	B	W	F	E
WR04X	1.20±0.10	0.7±0.10	8.00±0.20	3.50±0.05	1.75±0.10

Series No.	P1	P0	ΦD	T
WR04X	2.00±0.10	4.00±0.10	Φ1.50 ^{+0.1} _{-0.0}	0.40±0.05

Reel dimensions

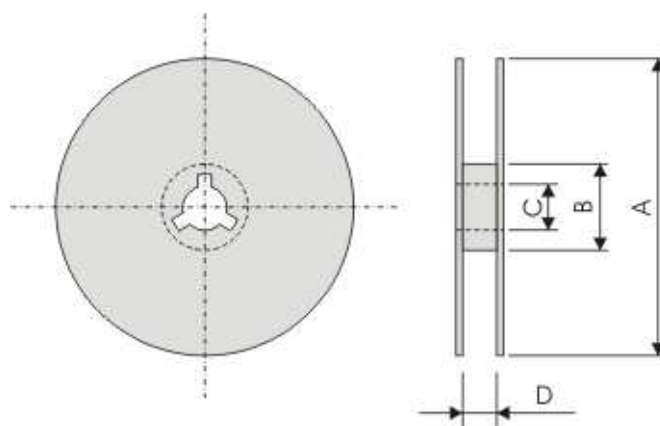

Symbol	A	B	C	D
(unit : mm)	Φ178.0±2.0	Φ60.0±1.0	13.0±0.2	9.0±0.5

Taping quantity and Tape material

- Chip resistors 10,000 pcs/reel, Paper tape.